

No	φD	L	SETS	NOTES
1				
2				
3				
4				
5				

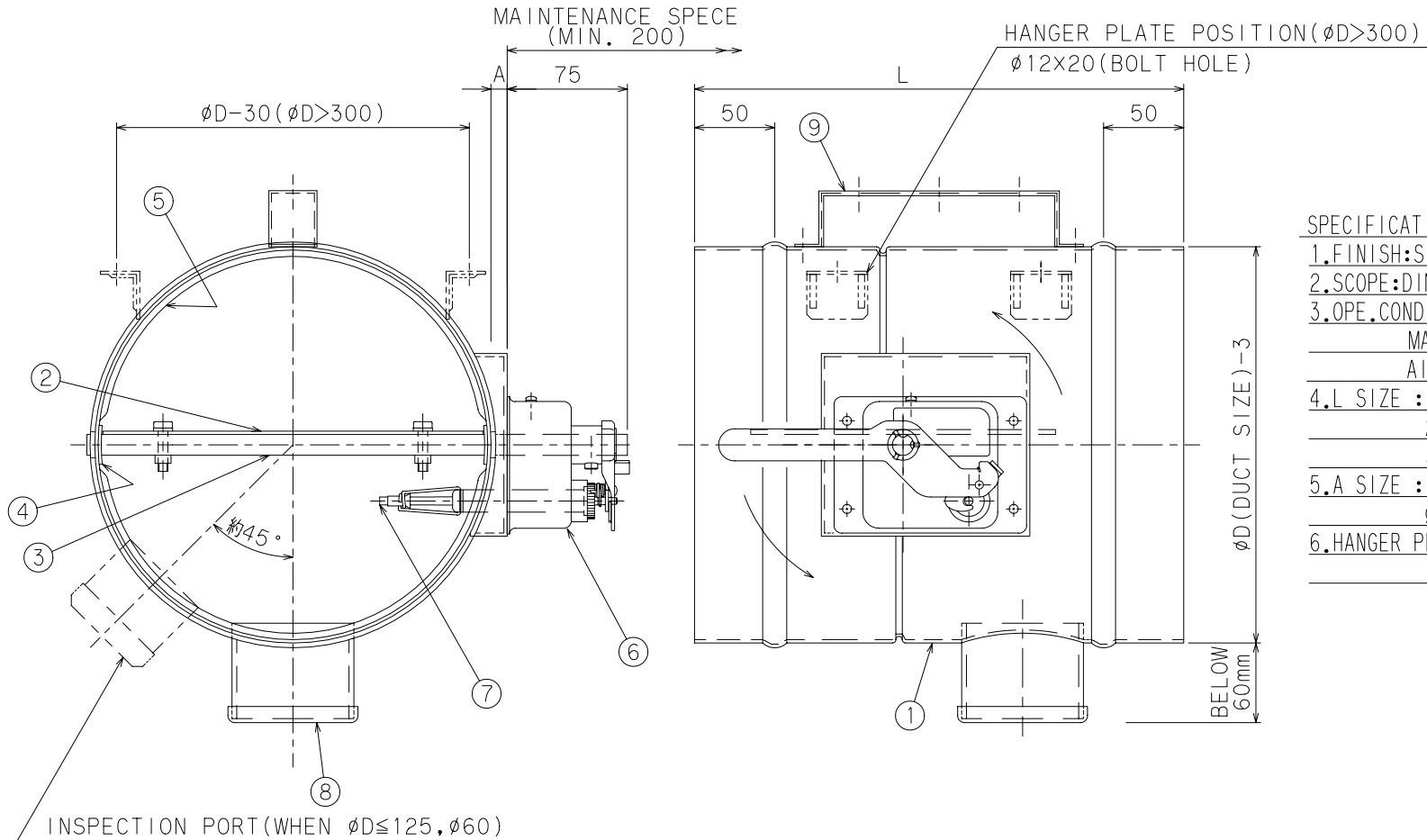

SPECIFICATION

1. FINISH: SILVER ON WELDED PORTION

2. SCOPE: DIM. φD: 100~450mm

3. OPE. CONDITION

MAX. STATIC PRESS. BELOW 800Pa

AIR SPEED: BELOW 10m/s

4. L SIZE : φD ≤ 250mm, L=300mm

275 ≤ φD ≤ 350mm, L=350mm

375 ≤ φD ≤ 450mm, L=450mm

5. A SIZE : φD=100, A=36mm

φD ≥ 125, A=15mm

6. HANGER PLATE: TO BE SUPPLIED ON REQUEST

ACTUATOR SPECIFICATION
RETAINING FORCE : 8.5N·m

OPERATION
THE DAMPER IS INSTANTANEOUSLY CLOSED WHEN THE TEMPERATURE FUSE HAS BLOWN.

RESETTING
REPLACE WITH A NEW TEMPERATURE FUSE, AND MANUALLY OPEN THE DAMPER.

9	HANGER PLATE	SPCC	1.5t, φ12x30, GALVANIZED
8	INSPECTION PORT	SPCC	φ76 OR φ60), GALVANIZED
7	THERMAL FUSE		72℃
6	ACTUATOR	SPCC	KGK-FD, GALVANIZED
5	STOPPER	SGCC	1.6t
4	BUSSING	BRASS	
3	SHAFT	SGDB	φ12.7, GALVANIZED
2	BLADE	SGCC	1.6t
1	CASING	SGCC	1.6t
No	名称	材質	備考

CUSTOMER	FORM	KGK-FD	SCALE	DESIGN	DRAW	EXAM.	APPRO.	KUCHO GIKEN KOGYO CO.,LTD.	3611773
CLASSIFICATION	SUBJECT	FIRE DAMPER	ANGLE	K. YAMANO	K. YOSHIZUMI	K. YAMANO	T. ITOI	DRAWING NO.	3611773-A
			2008.9.30.						